

Industrial Hydraulic Pumps T67DBB

Hydraulic Pumps

 Parker



Industrial Hydraulic Pumps T67DBB

Hydraulic Pumps

 Parker

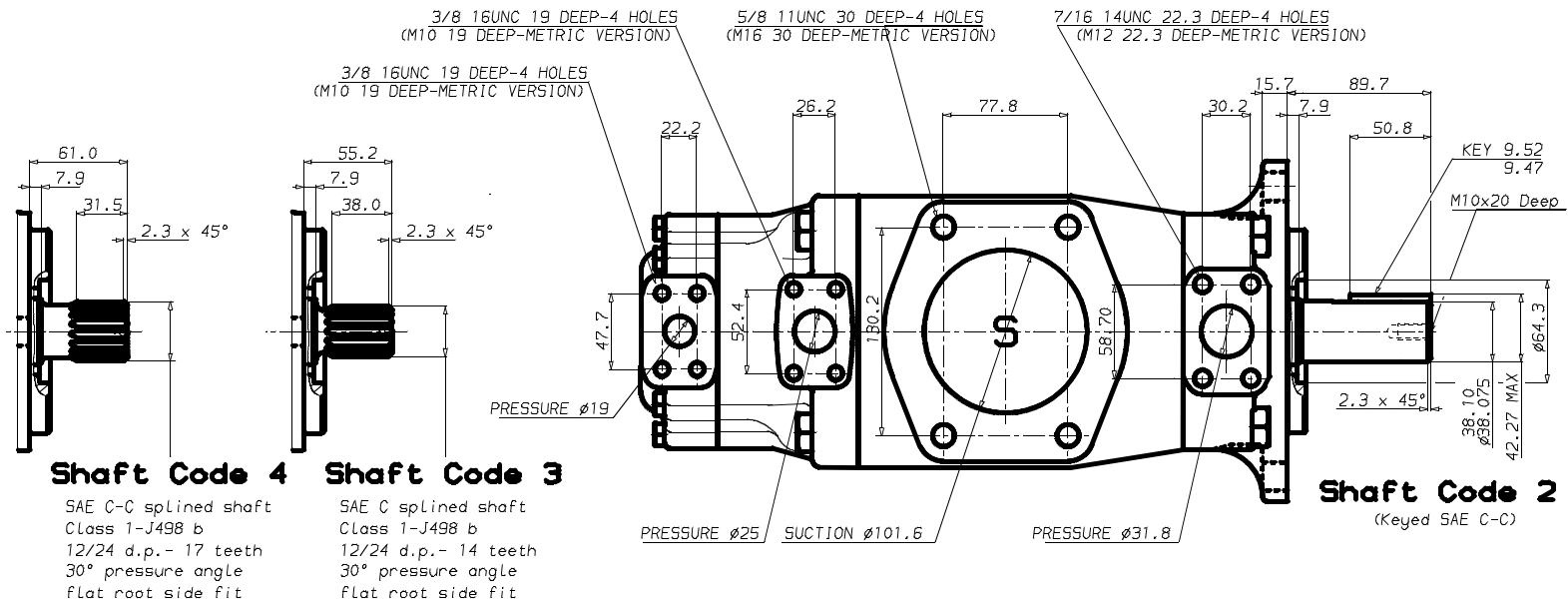
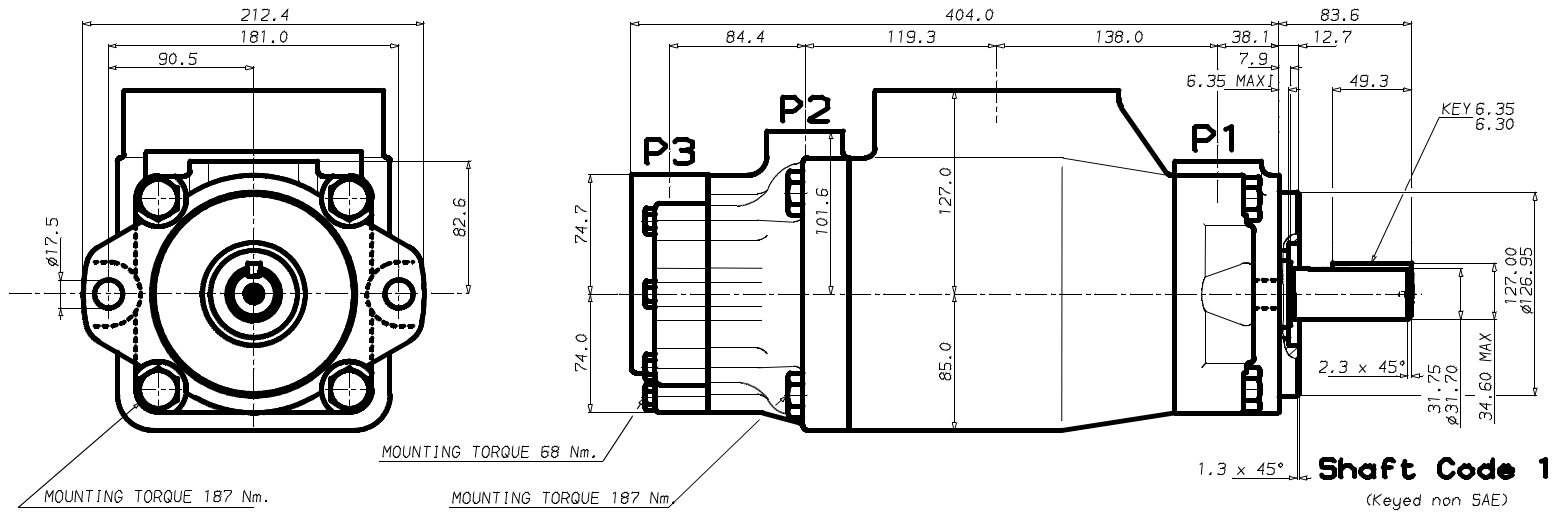

Shaft torque limits [ml/rev x bar]				
Pump	Shaft	Vi x p max. P1 + P2 + P3	Shaft	Vi x p max. P1 + P2 + P3
T67DBB	1	43240	3	61200
T67DCB	2	66500	4	66500