

Industrial Hydraulic Pumps T67DC, T67DCW

Hydraulic Pumps



Industrial Hydraulic Pumps T67DC, T67DCW

Hydraulic Pumps



Model No.

T67DC W - B42 - 010 - 1 R 00 - A 1 M1 - ..

Series - SAE C 2 bolts
J744 mounting flange

Severe duty shaft option

Displacement P1

Volumetric displacement (ml/rev.)

- B14 = 44,0 B31 = 99,2
- B17 = 55,0 B35 = 113,4
- B20 = 66,0 B38 = 120,6
- B22 = 70,3 B42 = 137,5
- B24 = 81,1 045 = 145,7
- B28 = 90,0 050 = 158,0

Displacement P2

Volumetric displacement (ml/rev.)

- 003 = 10,8 017 = 58,3
- 005 = 17,2 020 = 63,8
- 006 = 21,3 022 = 70,3
- 008 = 26,4 025 = 79,3
- 010 = 34,1 028 = 88,8
- 012 = 37,1 031 = 100,0
- 014 = 46,0

Type of shaft

- 1 = keyed (SAE C) 3 = splined (SAE C) 14 teeth
- 2 = keyed (non SAE) 4 = splined (spec. SAE C)

Type of shaft - Severe duty (T67DCW only)

- 5 = keyed (non SAE)

Modifications

Mounting w/connection variables

4 bolts SAE flanges J518

	Metric thread		UNC thread	
	M0	M1	00	01
P1	1.1/4"	1.1/4"	1.1/4"	1.1/4"
P2	1"	3/4"	1"	3/4"
S	3"	3"	3"	3"

Seal class

- 1 = S1 BUNA N - 0,7 bar max. (for mineral oil)
- 4 = S4 EPDM - 7 bar max. (for fire resistant fluids)
- 5 = S5 VITON® - 7 bar max. (for mineral oil and fire resistant fluids)

Design letter

Porting combination (see page 72)

00 = standard

Direction of rotation (shaft end view)

- R = Clockwise
- L = Counter-clockwise

INTERNAL LEAKAGE (TYPICAL)

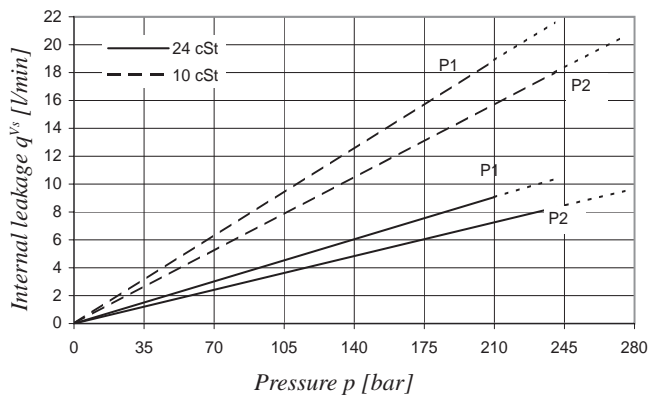

Do not operate pump more than 5 seconds at any speed or viscosity if internal leakage is higher than 50% of theoretical flow. Total leakage is the sum of each section loss under its respective operating conditions.

NOISE LEVEL (TYPICAL) - T67DC - B31 - 022

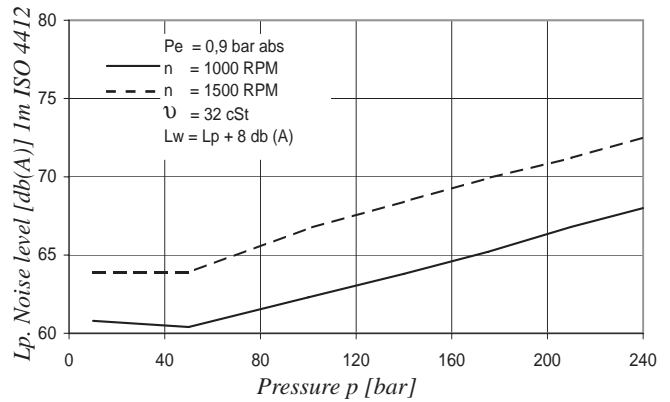

Double pump noise level is given with both stages section discharging at the pressure value indicated on the curve.

POWER LOSS HYDROMECHANICAL (TYPICAL)

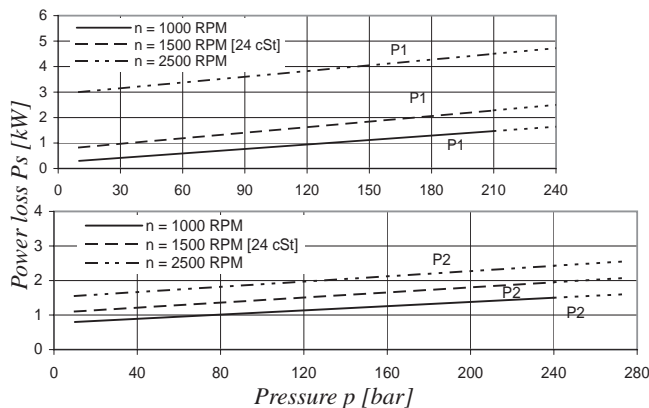

Total hydromechanical power loss is the sum of each section loss under its respective operating conditions.

PERMISSIBLE RADIAL LOAD

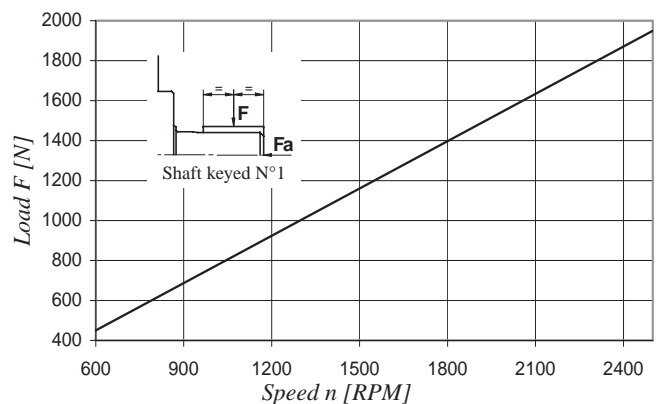

Maximum permissible axial load Fa = 1200 N



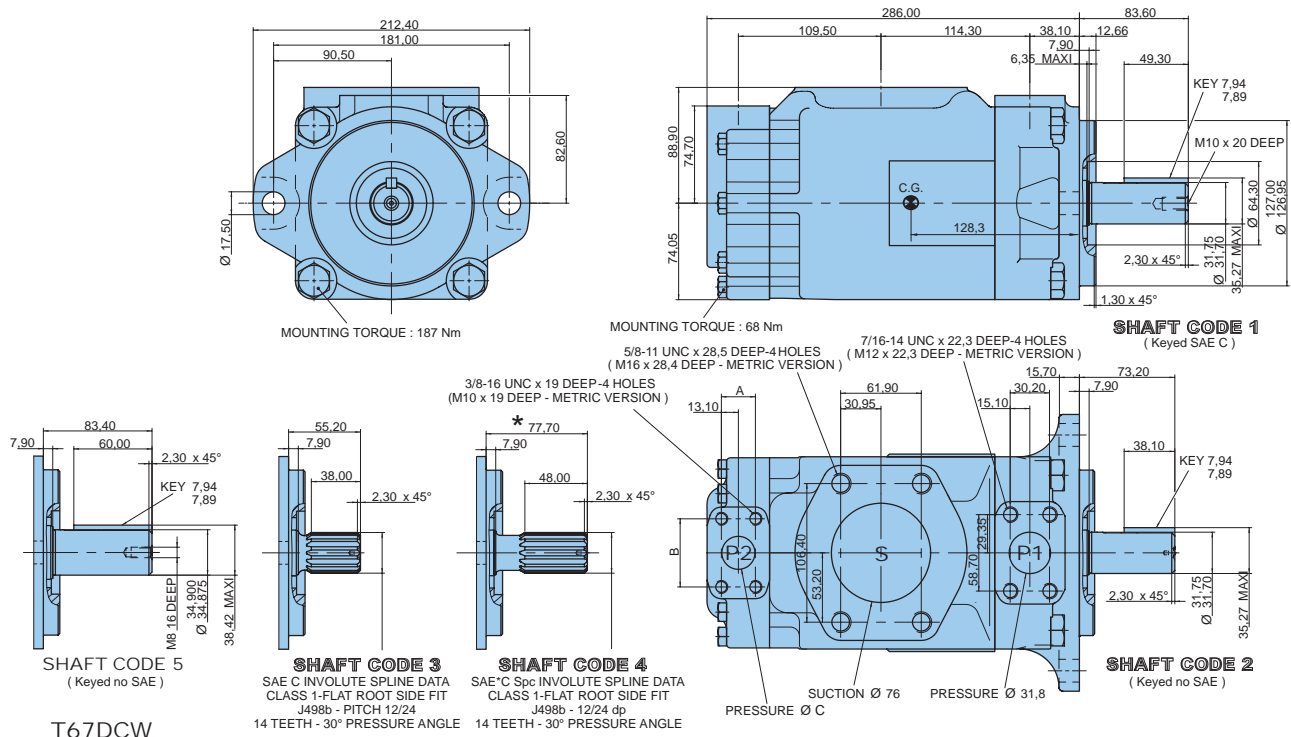

T67DCW

Alternate connect. variables		
	00 & M0	01 & M1
A	26.20	22.20
B	52.35	47.60
C	25.00	19.00

Shaft torque limits [ml/rev. x bar]			
Shaft	Vi x p max.	Shaft	Vi x p max.
1	43240	4	61200
2	34590	5	55600
3	61200		

OPERATING CHARACTERISTICS - TYPICAL [24 cSt]

Pressure port	Series	Vi Volumetric displacement	Flow q_v [l/min] & n = 1500 RPM			Input power P [kW] & n = 1500 RPM		
			p = 0 bar	p = 140 bar	p = 250 bar	p = 7 bar	p = 140 bar	p = 250 bar
P1	B14	44,0 ml/rev	66,0	59,4	54,2	1,5	16,6	29,0
	B17	55,0 ml/rev	82,5	75,9	70,7	1,7	20,4	35,8
	B20	66,0 ml/rev	99,0	92,4	87,2	1,9	24,3	42,7
	B22	70,3 ml/rev	105,5	98,8	93,7	2,0	25,8	45,4
	B24	81,1 ml/rev	121,7	115,0	109,9	2,2	29,5	52,1
	B28	90,0 ml/rev	135,0	128,4	123,2	2,3	32,7	57,7
	B31	99,2 ml/rev	148,8	142,2	137,0	2,5	35,9	63,5
	B35	113,4 ml/rev	170,1	163,5	158,3	2,7	40,8	72,3
	B38	120,6 ml/rev	180,9	174,3	169,1	2,9	43,4	76,8
	B42	137,5 ml/rev	206,3	199,6	194,5	3,2	49,3	87,4
	045	145,7 ml/rev	218,6	209,2	202,6 ²⁾	4,1	52,8	89,5 ²⁾
	050	158,0 ml/rev	237,0	227,7	223,0 ¹⁾	4,4	57,1	85,0 ¹⁾
			p = 0 bar	p = 140 bar	p = 275 bar	p = 7 bar	p = 140 bar	p = 275 bar
P2	003	10,8 ml/rev	16,2	11,2	*	1,3	5,3	*
	005	17,2 ml/rev	25,8	20,8	16,1	1,4	7,5	13,9
	006	21,3 ml/rev	31,9	26,9	22,2	1,5	8,9	16,8
	008	26,4 ml/rev	39,6	34,6	29,9	1,6	10,7	20,3
	010	34,1 ml/rev	51,1	46,1	41,4	1,7	13,4	25,6
	012	37,1 ml/rev	55,6	50,6	45,9	1,7	14,4	27,6
	014	46,0 ml/rev	69,0	64,0	59,3	1,9	17,6	33,7
	017	58,3 ml/rev	87,4	82,4	77,7	2,1	21,9	42,2
	020	63,8 ml/rev	95,7	90,7	86,0	2,2	23,8	46,0
	022	70,3 ml/rev	105,4	100,4	95,7	2,3	26,1	50,4
	025	79,3 ml/rev	118,9	113,9	109,2	2,5	29,2	56,6
	028	88,8 ml/rev	133,2	128,2	125,8 ¹⁾	2,8	32,7	48,5 ¹⁾
	031	100,0 ml/rev	150,0	145,0	142,6 ¹⁾	2,8	36,5	54,4 ¹⁾

* We do not recommend to use the size 003 in P2 at 275 bar & 1500 RPM as the internal leakage is over 50% of theoretical flow.

¹⁾ 050 - 028 - 031 = 210 bar max. int. ²⁾ 045 = 240 bar max. int.

