

Mobile Hydraulic Pumps T67GB

Hydraulic Pumps



Mobile Hydraulic Pumps T67GB

Hydraulic Pumps



Model No. **T67GB - B15 - 6 R 00 - A 1 - 00 -**

Series

Cam ring

(Delivery at 0 bar & 1500 r.p.m.)

B02 = 8,7 l/min B07 = 33,7 l/min
 B03 = 14,7 l/min B08 = 37,4 l/min
 B04 = 19,2 l/min B10 = 47,7 l/min
 B05 = 23,9 l/min B12 = 61,5 l/min
 B06 = 29,7 l/min B15 = 75,0 l/min

Type of shaft

6 = splined (DIN 5462)

Direction of rotation (view on shaft end)

R = clockwise

L = counter-clockwise

Modification

Mounting W/connection variables

Code	UNC		Metric	
	00	01	M0	M1
S = 1.1/2"	SAE	SAE	SAE	SAE
P = 1"	BSPP	SAE	BSPP	SAE

Seal class

1 = S1 - BUNA N

Design letter

Porting combination

00 = standard

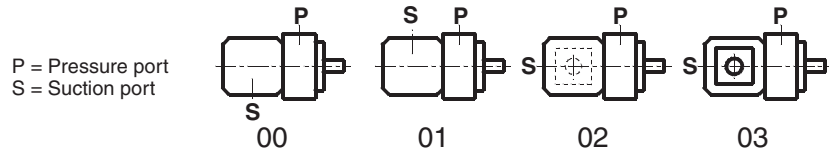

OPERATING CHARACTERISTICS - TYPICAL [24 cSt]

Series	Volumetric Displacement Vi	Speed n [R.P.M.]	Flow Q [l/min]			Input power P [kW]		
			p = 0 bar	p = 140 bar	p = 300 bar	p = 7 bar	p = 140 bar	p = 300 bar
B02	5,8 ml/rev	1000	5,8	4,1	-	0,2	1,6	-
		1500	8,7	7,0	5,1	0,5	2,6	5,1
B03	9,8 ml/rev	1000	9,8	8,1	6,2	0,2	2,5	5,3
		1500	14,7	13,0	11,1	0,6	4,0	8,1
B04	12,8 ml/rev	1000	12,8	11,1	9,2	0,3	3,2	6,8
		1500	19,2	17,5	15,6	0,6	5,0	10,4
B05	15,9 ml/rev	1000	15,9	14,2	12,3	0,3	4,0	8,4
		1500	23,9	22,2	20,2	0,7	6,1	12,7
B06	19,8 ml/rev	1000	19,8	18,1	16,2	0,3	4,9	10,3
		1500	29,7	28,0	26,1	0,7	7,5	15,6
B07	22,5 ml/rev	1000	22,5	20,8	19,0	0,4	5,5	11,8
		1500	33,7	32,0	30,2	0,8	8,5	17,6
B08	24,9 ml/rev	1000	24,9	23,2	21,3	0,4	6,1	12,9
		1500	37,4	35,7	33,7	0,8	9,3	19,5
B10	31,8 ml/rev	1000	31,8	30,1	28,2	0,5	7,7	16,3
		1500	47,7	46,0	44,1	0,9	11,7	24,6
B12	41,0 ml/rev	1000	41,0	39,3	37,4	0,6	9,8	20,9
		1500	61,5	59,8	57,9	1,1	14,9	31,5
B15	50,0 ml/rev	1000	50,0	48,3	46,6 ¹⁾	0,7	11,9	23,7 ¹⁾
		1500	75,0	73,3	71,6 ¹⁾	1,3	18,1	35,7 ¹⁾

¹⁾ B15 = 280 bar max. int.

- Not to use if the internal leakage greater than 50% of the theoretical flow.

Mobile Hydraulic Pumps

T67GB

Hydraulic Pumps



INTERNAL LEAKAGE (TYPICAL)

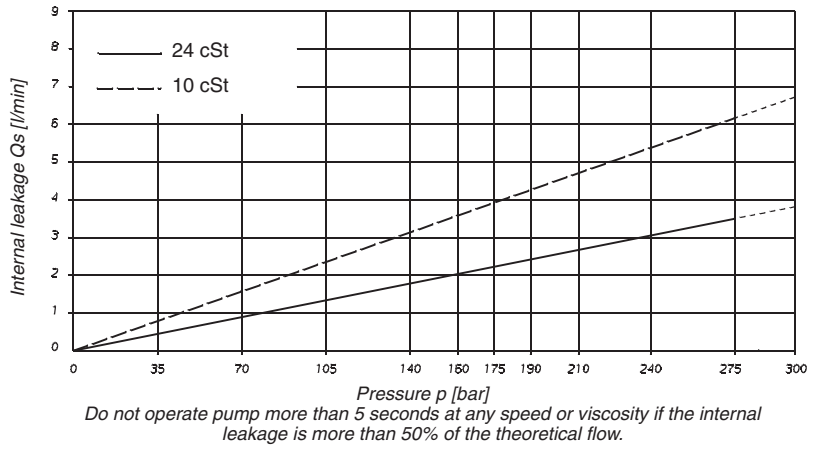

NOISE LEVEL (TYPICAL) T67GB - B10

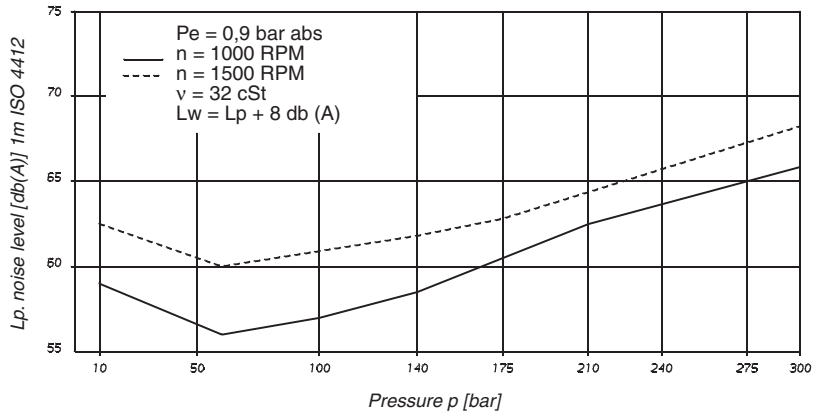

POWER LOSS HYDROMECHANICAL (TYPICAL)

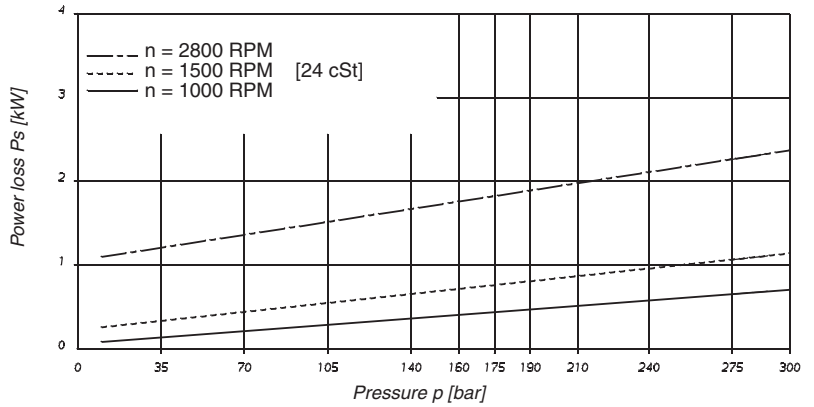

PERMISSIBLE RADIAL LOAD

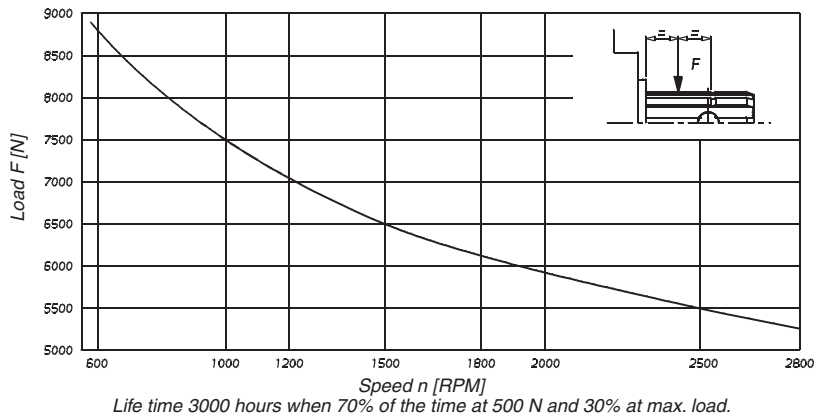

Mobile Hydraulic Pumps
T67GB

Hydraulic Pumps



Weight 18.0 kg

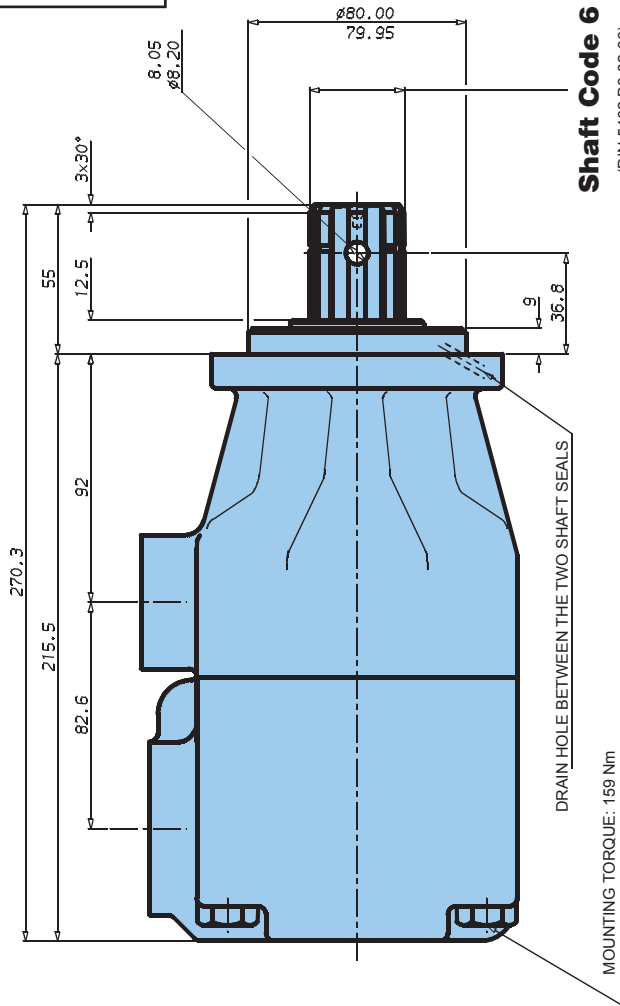

Shaft Code 6
(DIN 5462 B8-32-36)

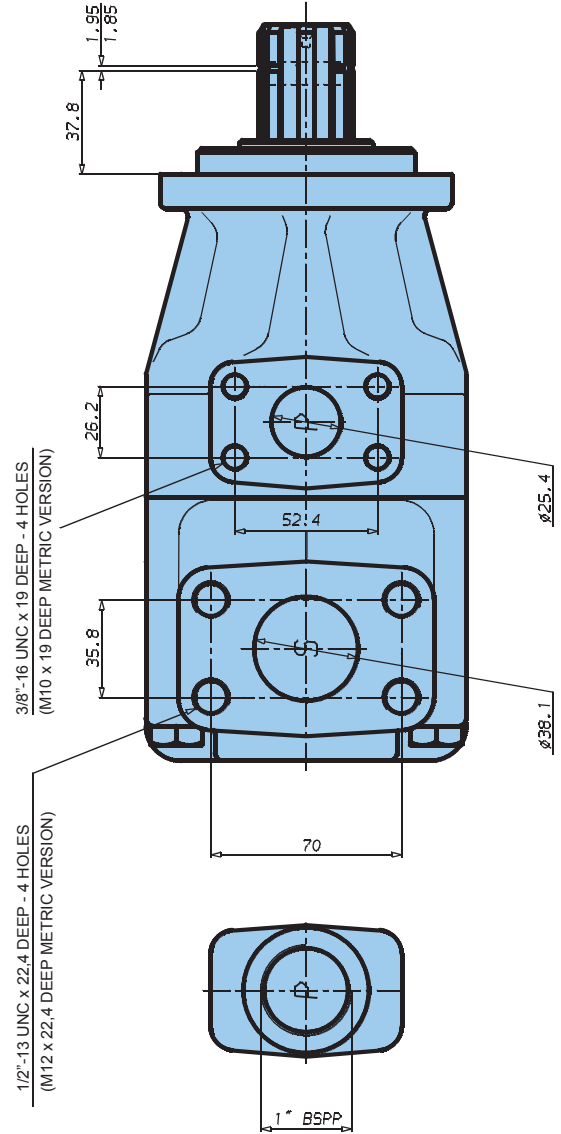
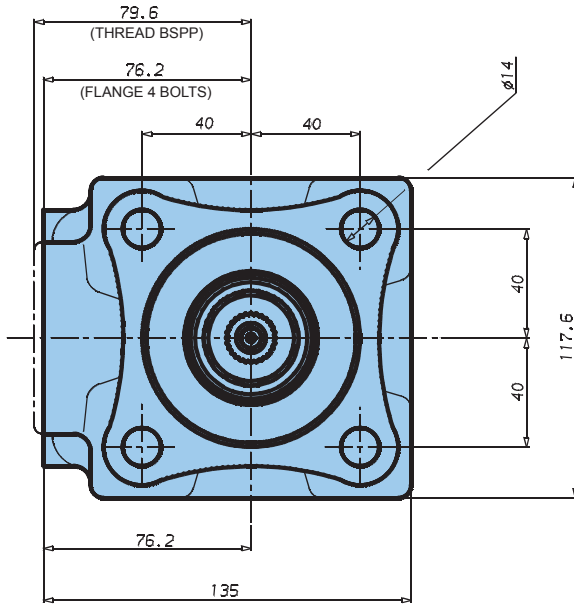

Mobile Hydraulic Pumps T67GB

Hydraulic Pumps

