

Industrial Hydraulic Pumps T6EE, T6EES

Hydraulic Pumps

Parker



Industrial Hydraulic Pumps T6EE, T6EES

Hydraulic Pumps

Parker

Model No.

T6EE or T6EES - 066 - 045 - 1 R 00 - A 1 0 - 00 - ..

T6EE series - 250 B4HW
ISO 3019-2 mounting flange
T6EES series - SAE E 4 bolts
Mounting flange J744c

Displacement P1 and P2

042 = 132,3 ml/rev
045 = 142,4 ml/rev
050 = 158,5 ml/rev
052 = 164,8 ml/rev
062 = 196,7 ml/rev
066 = 213,3 ml/rev
072 = 227,1 ml/rev
085 = 268,0 ml/rev

Type of shaft T6EE

2 = keyed G45N (ISO 3019-2)

Type of shaft T6EES

1 = keyed (SAE CC)
3 = splined (SAE CC)
4 = splined (SAE D & E)
5 = keyed (SAE D & E)

Modifications

Mounting w/connection variables

	P1 & P2 = 1 ^{3/2} - S = 4 ^{3/2}	
	UNC	Metric
T6EE		M0
T6EES	00	M0

Coupling adaptor

0 = none
2 = SAE B
3 = SAE BB

Seal class

1 = S1 - BUNA N
4 = S4 - EPDM
5 = S5 - VITON

Design letter

Porting combination

00 = standard

Direction of rotation (view on shaft end)

R = Clockwise
L = Counter-clockwise

INTERNAL LEAKAGE (TYPICAL)

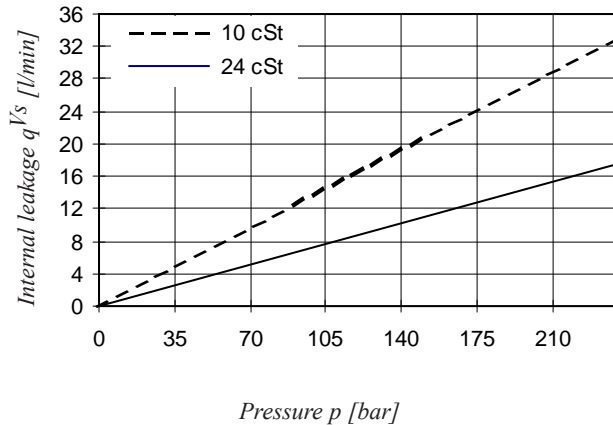

Do not operate pump more than 5 seconds at any speed or viscosity if internal leakage is higher than 50% of theoretical flow. Total leakage is the sum of each section loss at its operating conditions.

**NOISE LEVEL (TYPICAL)
T6EE 050 - 050**

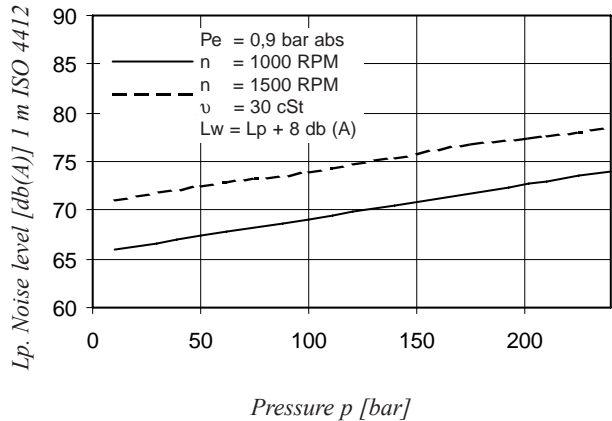

Double pump noise level is given with each section discharging at the pressure noted on the curve.

POWER LOSS HYDROMECHANICAL (TYPICAL)

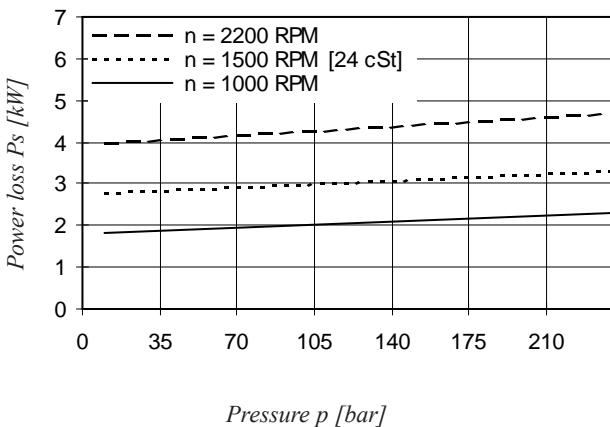

Total hydromechanical power loss is the sum of each section at its operating conditions.

PERMISSIBLE RADIAL LOAD

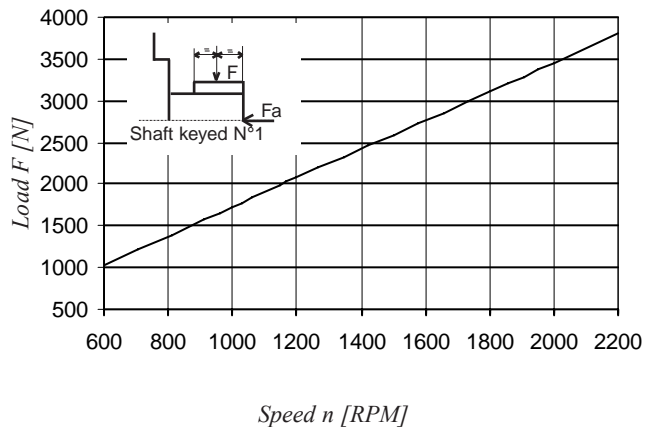

Maximum permissible axial load $F_a = 2000$ N

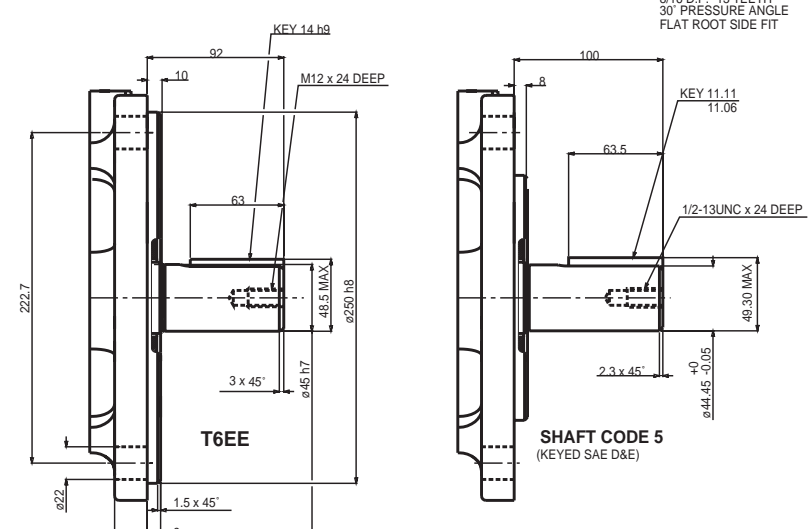
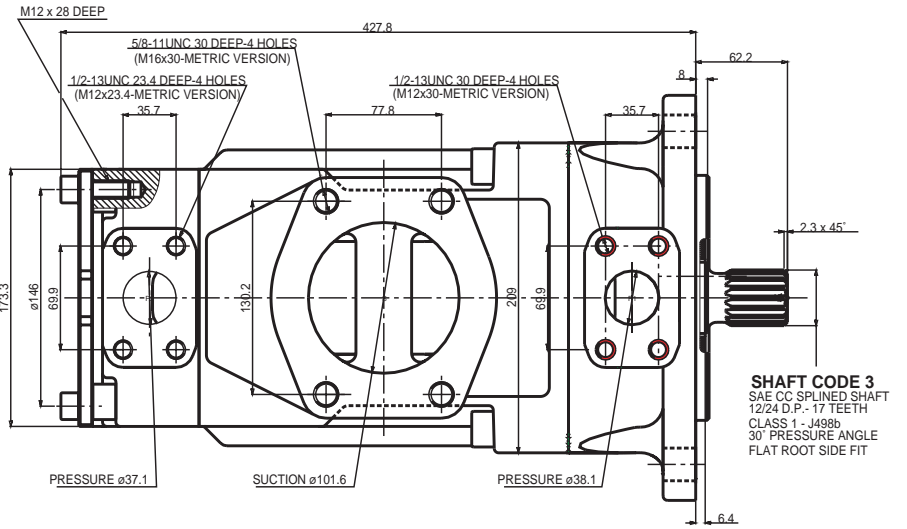
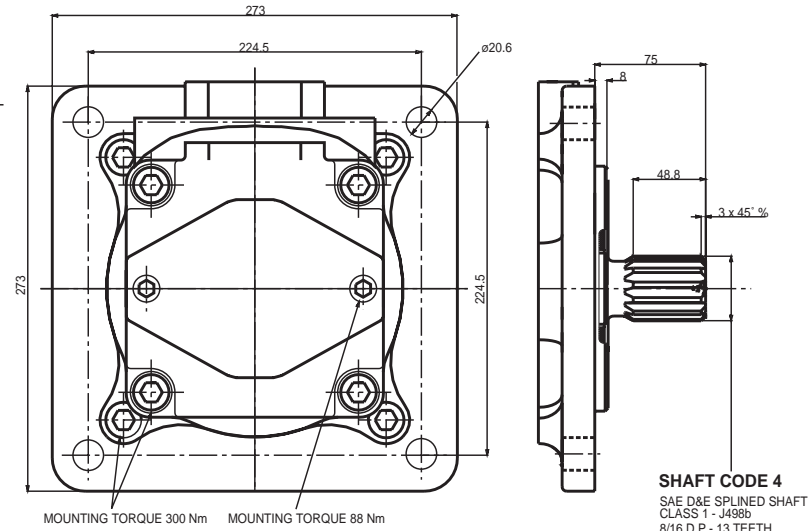
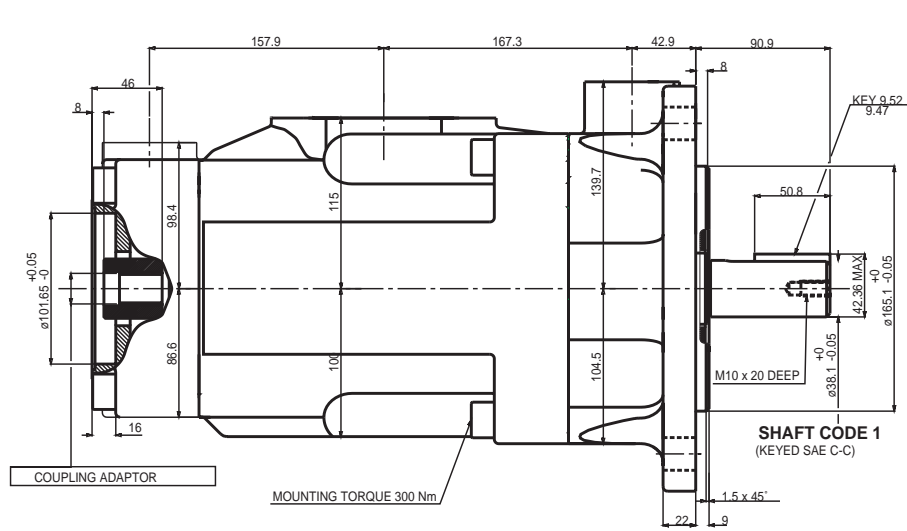

Shaft torque limits [ml/rev x bar]			
Shaft	Vi x p max.	Coupling	Vi x p max.
1	72300	SAE B	20600
2	114600	SAE BB	32670
3	126800		
4	126800		
5	118340		

DIMENSIONS & OPERATING CHARACTERISTICS - Weight : 95 kg - T6EE AND T6EES SERIES