

Industrial Hydraulic Pumps T7ED, T7EDS

Hydraulic Pumps

 Parker



Industrial Hydraulic Pumps T7ED, T7EDS

Hydraulic Pumps

 Parker

Model No.

T7ED or T7EDS - 042 - B22 - 1 R 00 - A 1 M0 - ..

T7ED series - ISO 2 bolts 3019-2
mounting flange 125 A2 HW

T7EDS series - SAE C 2 bolts
J744 mounting flange

P1 P2

Displacement P1

Volumetric displacement (ml/rev.)

042 = 132,3 057 = 183,3

045 = 142,4 062 = 196,7

050 = 158,5 066 = 213,3

052 = 164,8 072 = 227,1

054 = 171,0 085 = 268,7

Displacement P2

Volumetric displacement (ml/rev.)

B14 = 44,0 B31 = 99,2

B17 = 55,0 B35 = 113,4

B20 = 66,0 B38 = 120,6

B22 = 70,3 B42 = 137,5

B24 = 81,1 045 = 145,7

B28 = 90,0 050 = 158,0

Type of shaft T7EDS

1 = keyed (SAE CC) 3 = splined (SAE C) 14 teeth
2 = keyed (non SAE) 4 = splined (SAE CC) 17 teeth

Type of shaft T7ED - T7EDS

5 = keyed (ISO R775 - G38M)

Modifications

Mounting w/connection variables

4 bolts SAE flanges J518

P1 = 1.1/2" - P2 = 1.1/4" - S = 4"		
	T7ED - T7EDS	T7EDS
Type	Metric thread	UNC thread
Code	M0	00

Seal class

1 = S1 BUNA N - 0,7 bar max. (for mineral oil)
4 = S4 EPDM - 7 bar max. (for fire resistant fluids)
5 = S5 VITON® - 7 bar max. (for mineral oil and fire resistant fluids)

Design letter

Porting combination (see page 72)

00 = standard

Direction of rotation (shaft end view)

R = Clockwise
L = Counter-clockwise

INTERNAL LEAKAGE (TYPICAL)

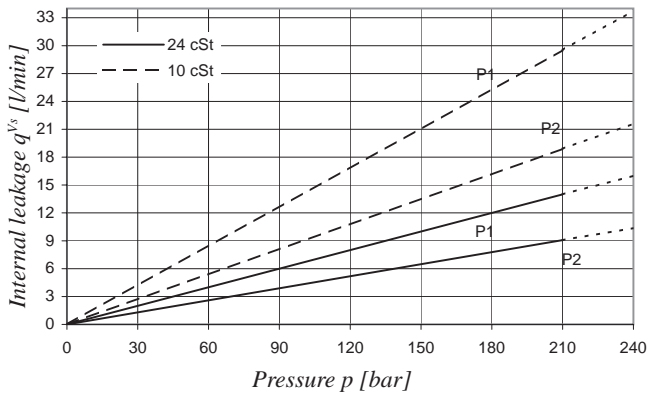

Do not operate pump more than 5 seconds at any speed or viscosity if internal leakage is higher than 50% of theoretical flow.
Total leakage is the sum of each section loss under its respective operating conditions.

NOISE LEVEL (TYPICAL) - T7EDS - 050 - B31

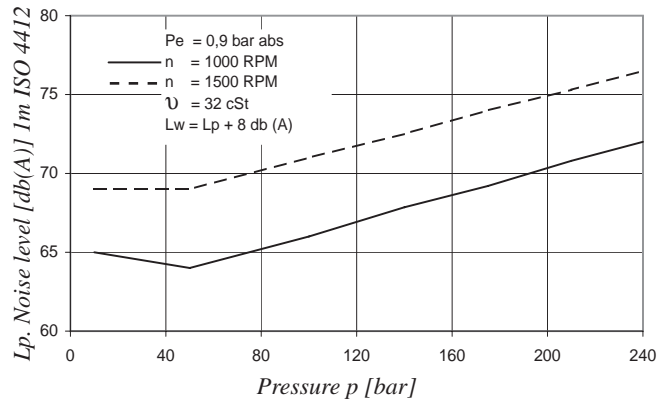

Double pump noise level is given with both stages discharging at the pressure value indicated on the curve.

POWER LOSS HYDROMECHANICAL (TYPICAL)

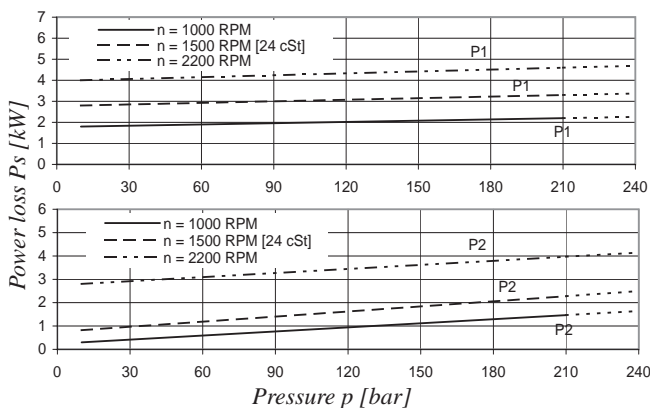

Total hydromechanical power loss is the sum of each section loss under its respective operating conditions.

PERMISSIBLE RADIAL LOAD

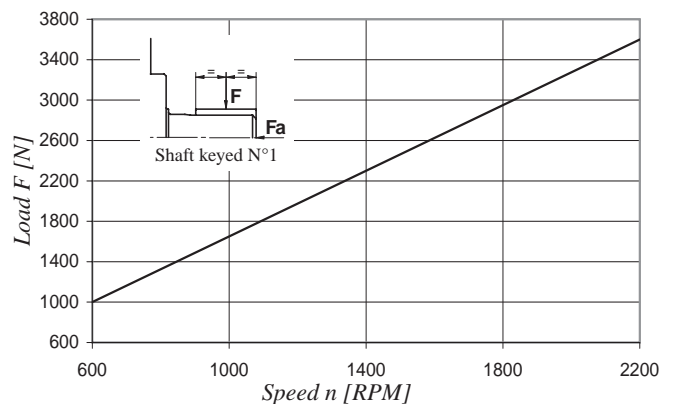

Maximum permissible axial load Fa = 2000 N



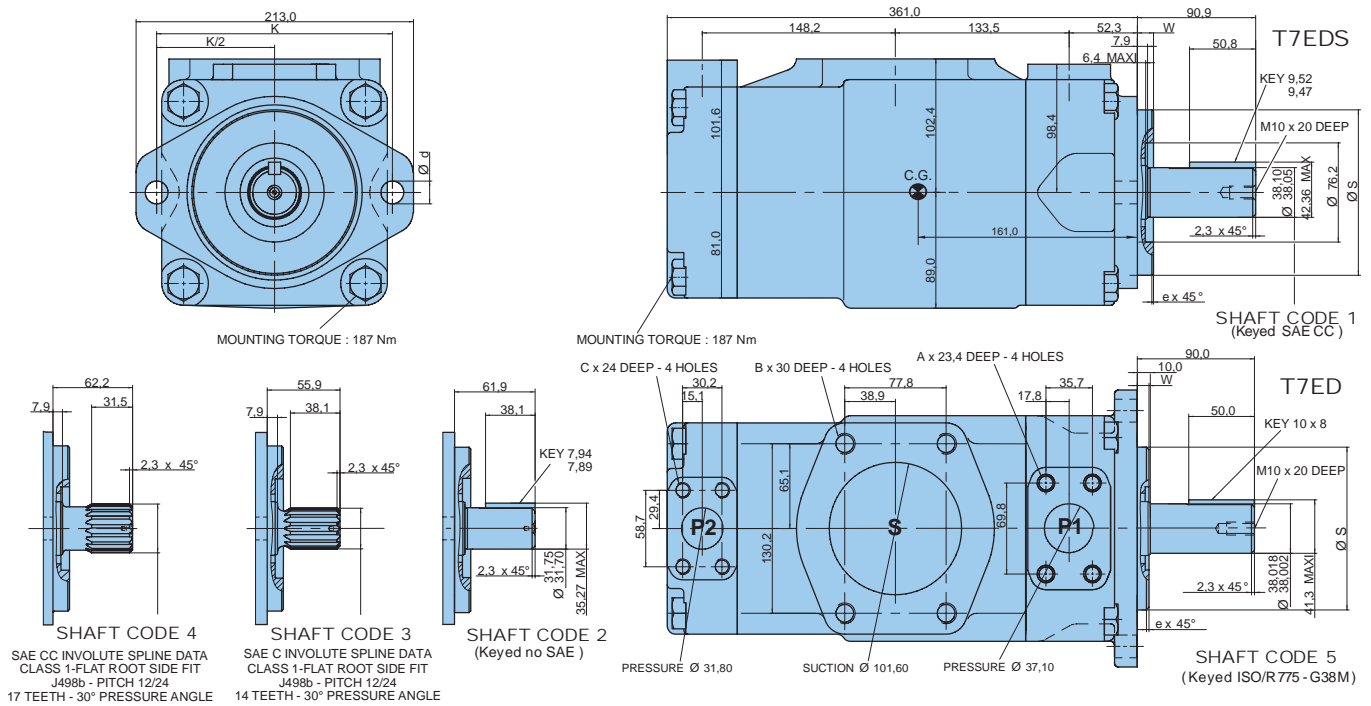

Alternate mounting flange						
	Dia S		e x 45°	W	K	Dia d
	Max.	Min.				
T7ED	125,000	124,937	2,0	9,5	180,0	18,0
T7EDS	127,000	126,950	1,3	12,7	181,0	17,5

Alternate connect. variables		
	01	M1
A	1/2" - 13 UNC	M12
B	5/8" - 11 UNC	M16
C	7/16" - 14 UNC	M12

Shaft torque limits [ml/rev. x bar]			
Shaft	Vi x p max.	Shaft	Vi x p max.
1	72300	4	68500
2	34590	5	68500
3	61200		

OPERATING CHARACTERISTICS - TYPICAL [24 cSt]

Pressure port	Series	Vi Volumetric displacement	Flow q _v [l/min] & n = 1500 RPM			Input power P [kW] & n = 1500 RPM		
			p = 0 bar	p = 140 bar	p = 240 bar	p = 7 bar	p = 140 bar	p = 240 bar
P1	042	132,3 ml/rev	198,5	188,5	181,3	5,2	49,4	82,6
	045	142,4 ml/rev	213,6	203,6	196,5	5,4	52,9	88,7
	050	158,5 ml/rev	237,7	227,7	220,6	5,7	58,5	98,3
	052	164,8 ml/rev	247,2	237,2	230,1	5,8	60,8	102,1
	054	171,0 ml/rev	256,5	246,5	239,4	5,9	63,0	105,8
	057	183,3 ml/rev	275,0	265,0	257,9	6,1	67,3	113,2
	062	196,7 ml/rev	295,0	285,0	277,9	6,4	71,9	121,3
	066	213,3 ml/rev	319,9	309,0	302,8	6,7	77,7	131,2
	072	227,1 ml/rev	340,6	330,6	323,5	6,9	82,6	139,5
	085	268,7 ml/rev	403,0	392,0 ¹⁾	-	9,1	65,8 ¹⁾	-
P2			p = 0 bar	p = 140 bar	p = 250 bar	p = 7 bar	p = 140 bar	p = 250 bar
	B14	44,0 ml/rev	66,0	59,4	54,2	1,5	16,6	29,0
	B17	55,0 ml/rev	82,5	75,9	70,7	1,7	20,4	35,8
	B20	66,0 ml/rev	99,0	92,4	87,2	1,9	24,3	42,7
	B22	70,3 ml/rev	105,5	98,8	93,7	2,0	25,8	45,4
	B24	81,1 ml/rev	121,7	115,0	109,9	2,2	29,5	52,1
	B28	90,0 ml/rev	135,0	128,4	123,2	2,3	32,7	57,7
	B31	99,2 ml/rev	148,8	142,2	137,0	2,5	35,9	63,5
	B35	113,4 ml/rev	170,1	163,5	158,3	2,7	40,8	72,3
	B38	120,6 ml/rev	180,9	174,3	169,1	2,9	43,4	76,8
	B42	137,5 ml/rev	206,3	199,6	194,5	3,2	49,3	87,4
	045	145,7 ml/rev	218,6	209,2	202,6 ³⁾	4,1	52,8	89,5 ³⁾
	050	158,0 ml/rev	237,0	227,7	223,0 ²⁾	4,4	57,1	85,0 ²⁾

¹⁾ 085 = 90 bar max. int.

²⁾ 050 = 210 bar max. int.

³⁾ 045 = 240 bar max. int.