

Industrial Hydraulic Pumps T7EB, T7EBS

Hydraulic Pumps

Parker



Industrial Hydraulic Pumps T7EB, T7EBS

Hydraulic Pumps

Parker

Model No. T7EB or T7EBS - 042 - B12 - 1 R 00 - A 1 M1 - ..

T7EB series - ISO 2 bolts 3019-2
 Mounting flange 125-A2 HW
T7EBS series - SAE C 2 bolts
 J744 mounting flange

Displacement P1

Volumetric displacement (ml/rev.)
 042 = 132,3 057 = 183,3
 045 = 142,4 062 = 196,7
 050 = 158,5 066 = 213,3
 052 = 164,8 072 = 227,1
 054 = 171,0 085 = 268,7

Displacement P2

Volumetric displacement (ml/rev.)
 B02 = 5,8 B09 = 28,0
 B03 = 9,8 B10 = 31,8
 B04 = 12,8 B11 = 35,0
 B05 = 15,9 B12 = 41,0
 B06 = 19,8 B14 = 45,0
 B07 = 22,5 B15 = 50,0
 B08 = 24,9

Type of shaft T7EBS

1 = keyed (SAE CC) 3 = splined (SAE C) 14 teeth
 2 = keyed (non SAE) 4 = splined (SAE CC)

Type of shaft T7EB - T7EBS

5 = keyed (ISO /R 775 - G38 M)

Modifications

Mounting w/connection variables

4 bolts SAE flanges J518

P1 = 1.1/2" - P2 = 3/4" - S = 3.1/2"		
	Metric thread	UNC thread
	T7EB - T7EBS	T7EBS
Code	M1	01

Seal class

1 = S1 BUNA N - 0,7 bar max. (for mineral oil)
 4 = S4 EPDM - 7 bar max. (for fire resistant fluids)
 5 = S5 VITON® - 7 bar max. (for mineral oil and fire resistant fluids)

Design letter

Porting combination (see page 72)

00 = standard

Direction of rotation (shaft end view)

R = Clockwise
 L = Counter-clockwise

INTERNAL LEAKAGE (TYPICAL)

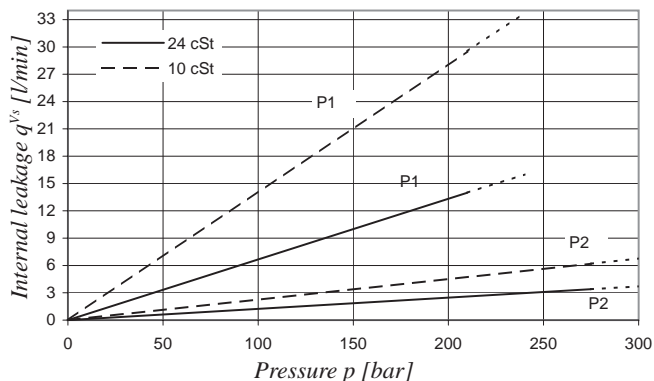

Do not operate pump more than 5 seconds at any speed or viscosity if internal leakage is higher than 50% of theoretical flow.

Total leakage is the sum of each section loss under its respective operating conditions.

NOISE LEVEL (TYPICAL) - T7EBS - 050 - B03

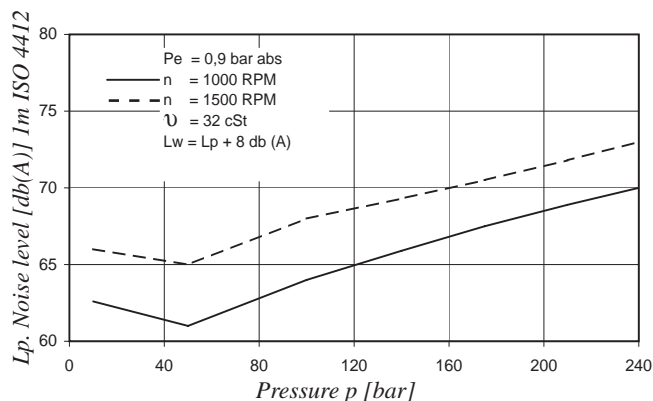

Double pump noise level is given with both stages discharging at the pressure value indicated on the curve.

POWER LOSS HYDROMECHANICAL (TYPICAL)

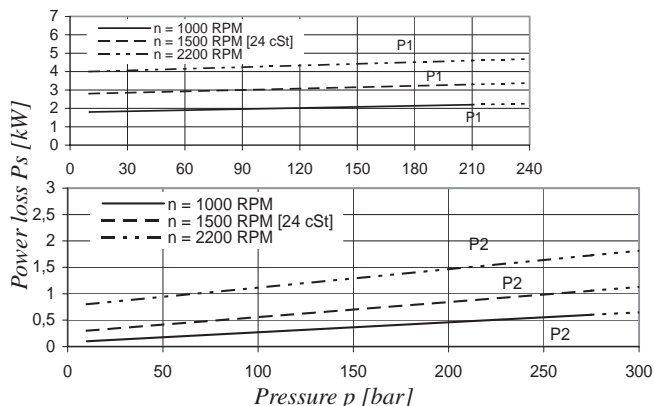

Total hydromechanical power loss is the sum of each section loss under its respective operating conditions.

PERMISSIBLE RADIAL LOAD

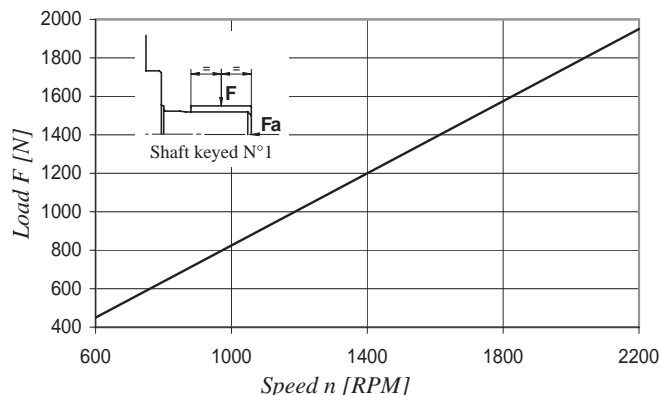

Maximum permissible axial load Fa = 2000 N



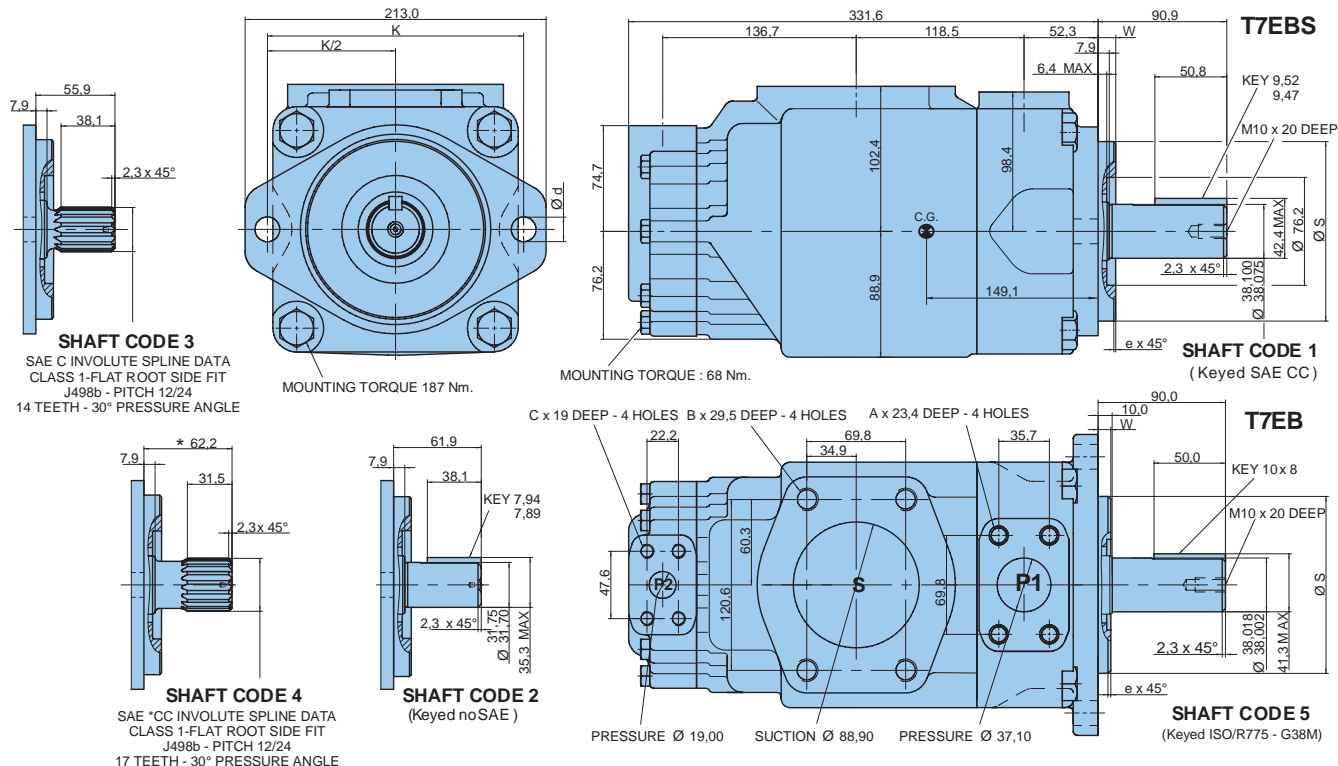

Alternate mounting flange						
	Dia S		e x 45°	W	K	Dia d
	Max.	Min.				
T7EB	125,000	124,937	2,0	9,5	180,0	18,0
T7EBS	127,000	126,950	1,3	12,7	181,0	17,5

Alternate connect. variables		
	01	M1
A	1/2" - 13 UNC	M12
B	5/8" - 11 UNC	M16
C	3/8" - 16 UNC	M10

Shaft torque limits [ml/rev. x bar]			
Shaft	Vi x p max.	Shaft	Vi x p max.
1	68500	4	68500
2	34590	5	68500
3	61200		

OPERATING CHARACTERISTICS - TYPICAL [24 cSt]

Pressure port	Series	Vi Volumetric displacement	Flow q _v [l/min] & n = 1500 RPM			Input power P [kW] & n = 1500 RPM		
			p = 0 bar	p = 140 bar	p = 240 bar	p = 7 bar	p = 140 bar	p = 240 bar
P1	042	132,3 ml/rev	198,5	188,5	181,3	5,2	49,4	82,6
	045	142,4 ml/rev	213,6	203,6	196,5	5,4	52,9	88,7
	050	158,5 ml/rev	237,7	227,7	220,6	5,7	58,5	98,3
	052	164,8 ml/rev	247,2	237,2	230,1	5,8	60,8	102,1
	054	171,0 ml/rev	256,5	246,5	239,4	5,9	63,0	105,8
	057	183,3 ml/rev	275,0	265,0	257,9	6,1	67,3	113,2
	062	196,7 ml/rev	295,0	285,0	277,9	6,4	71,9	121,3
	066	213,3 ml/rev	319,9	309,0	302,8	6,7	77,7	131,2
	072	227,1 ml/rev	340,6	330,6	323,5	6,9	82,6	139,5
	085	268,7 ml/rev	403,0	392,0 ¹⁾	-	9,1	65,8 ²⁾	-
P2			p = 0 bar	p = 140 bar	p = 300 bar	p = 7 bar	p = 140 bar	p = 300 bar
	B02	5,8 ml/rev	8,7	7,0	5,1	0,5	2,6	5,1
	B03	9,8 ml/rev	14,7	13,0	11,1	0,6	4,0	8,1
	B04	12,8 ml/rev	19,2	17,5	15,6	0,6	5,0	10,4
	B05	15,9 ml/rev	23,9	22,2	20,2	0,7	6,1	12,7
	B06	19,8 ml/rev	29,7	28,0	26,1	0,7	7,5	15,6
	B07	22,5 ml/rev	33,7	32,0	30,2	0,8	8,5	17,6
	B08	24,9 ml/rev	37,4	35,7	33,7	0,8	9,3	19,5
	B09	28,0 ml/rev	42,0	40,3	38,4	0,9	10,4	21,8
	B10	31,8 ml/rev	47,7	46,0	44,1	0,9	11,7	26,2
	B11	35,0 ml/rev	52,5	50,8	48,9	1,0	12,8	27,0
	B12	41,0 ml/rev	61,5	59,8	57,9	1,1	14,9	31,5
	B14	45,0 ml/rev	67,5	65,8	63,9	1,2	16,3	34,5
	B15	50,0 ml/rev	75,0	73,3	71,6 ²⁾	1,3	18,1	35,7 ²⁾

¹⁾ 085 = 90 bar max. int.

²⁾ B15 = 280 bar max.int.

