

Mobile Hydraulic Pumps T6CM

Hydraulic Pumps



Mobile Hydraulic Pumps T6CM

Hydraulic Pumps

Model No.

T6CM - B22 - 1 R 00 - C 1

Series M = Mobile 1 shaft seal

Cam ring

(Delivery at 0 bar & 1500 r.p.m.)

B03 = 16,2 l/min	B17 = 87,4 l/min
B05 = 25,8 l/min	B20 = 95,7 l/min
B06 = 31,9 l/min	B22 = 105,4 l/min
B08 = 39,6 l/min	B25 = 118,9 l/min
B10 = 51,1 l/min	B28 = 133,2 l/min
B12 = 55,6 l/min	B31 = 150,0 l/min
B14 = 69,0 l/min	

Type of shaft

- 1 = keyed (SAE B)
- 2 = keyed (no SAE)
- 3 = splined (SAE B)
- 4 = splined (SAE BB)

Modification

Seal class

- 1 = S1 (for mineral oil)
- 4 = S4 (for the resistant fluids)
- 5 = S5 (for mineral oil and fire resistant fluids)

Design letter

Porting combination

00 = standard

Direct. of rotation (view on shaft end)

- R = clockwise
- L = counter-clockwise

- P = Pressure port
- S = Suction port

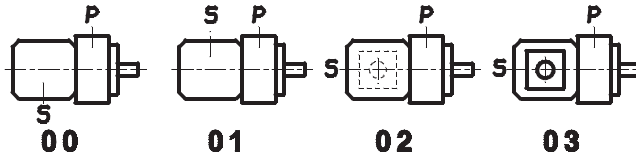

INTERNAL LEAKAGE (TYPICAL)

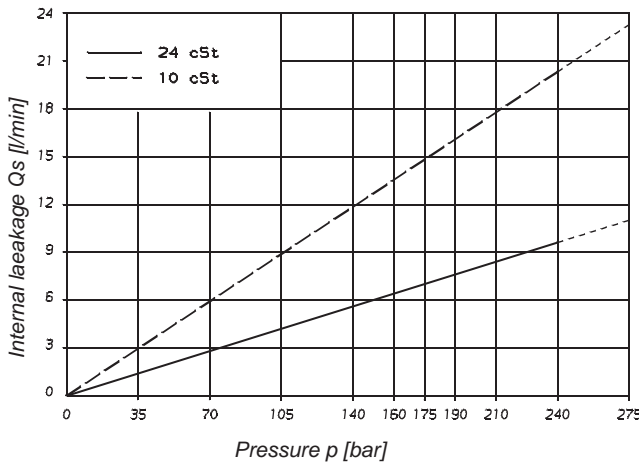

**NOISE LEVEL (TYPICAL)
T6CM - B22**

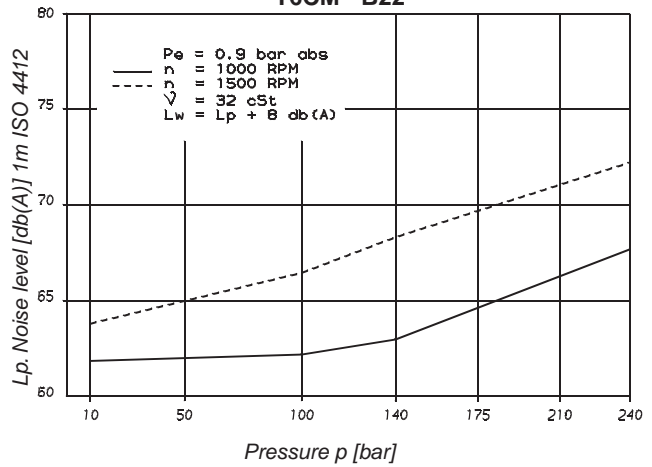

Do not operate the pump more than 5 seconds at any speed or viscosity if internal leakage is more than 50 % of theoretical flow.

POWER LOSS HYDROMECHANICAL (TYPICAL)

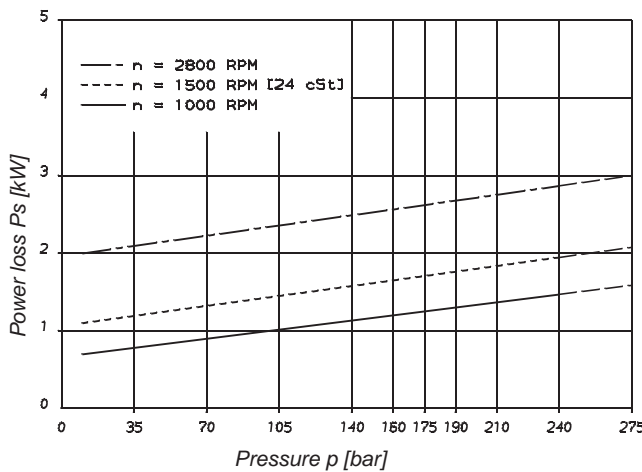

PERMISSIBLE RADIAL LOAD

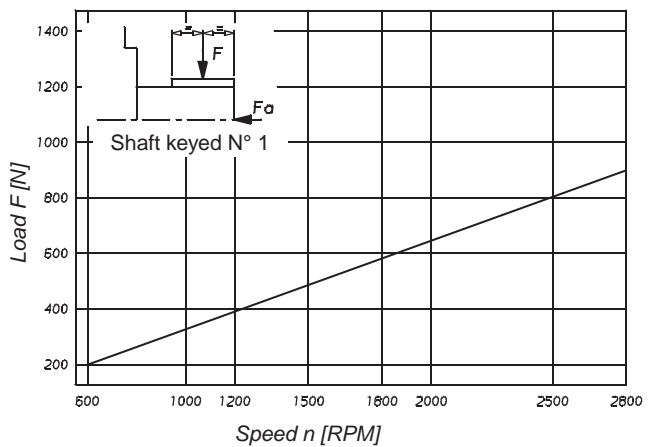

Maximum permissible axial load Fa = 800 N

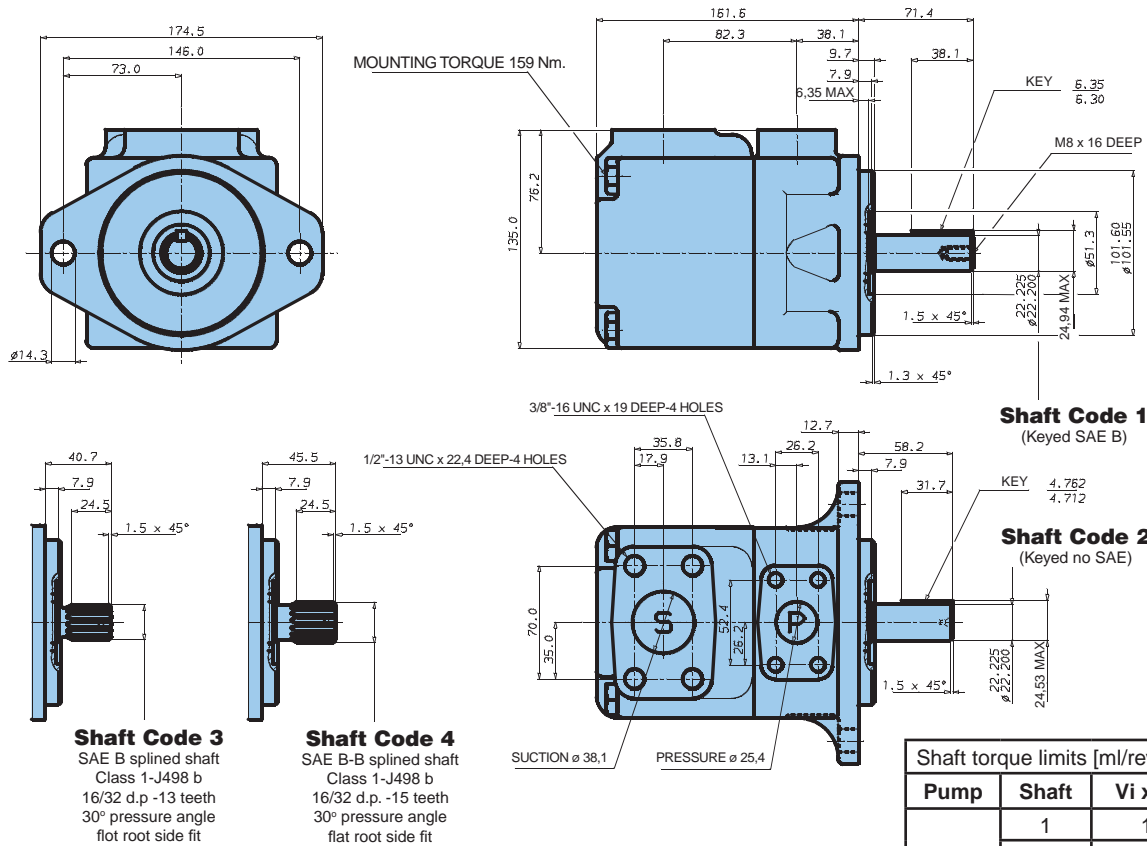

Shaft torque limits [ml/rev x bar]		
Pump	Shaft	Vi x p max.
T6CM	1	16500
	2	14300
	3	20600
	4	21800

OPERATING CHARACTERISTICS - TYPICAL [24 cSt]

Series	Volumetric Displacement Vi	Speed n [R.P.M.]	Flow Q [l/min]			Input power P [kW]		
			p = 0 bar	p = 140 bar	p = 240 bar	p = 7 bar	p = 140 bar	p = 240 bar
B03	10,8 ml/rev	1000	10,8	-	-	1,0	-	-
		1500	16,2	10,7	-	1,3	5,3	-
B05	17,2 ml/rev	1000	17,2	11,7	-	1,1	5,1	-
		1500	25,8	20,3	15,8	1,4	7,5	12,2
B06	21,3 ml/rev	1000	21,3	15,8	11,3	1,1	6,0	10,0
		1500	31,9	26,5	22,0	1,5	8,9	14,7
B08	26,4 ml/rev	1000	26,4	20,9	16,4	1,2	7,2	12,1
		1500	39,6	34,1	29,6	1,6	10,7	17,7
B10	34,1 ml/rev	1000	34,1	28,6	24,1	1,3	8,9	15,1
		1500	51,1	45,7	41,2	1,7	13,4	22,3
B12	37,1 ml/rev	1000	37,1	31,6	27,1	1,3	9,6	16,3
		1500	55,6	50,2	45,7	1,7	14,4	24,1
B14	46,0 ml/rev	1000	46,0	40,5	36,0	1,4	11,7	19,9
		1500	69,0	63,5	59,0	1,9	17,6	29,5
B17	58,3 ml/rev	1000	58,3	52,8	48,3	1,6	14,5	24,8
		1500	87,4	82,0	77,5	2,1	21,9	36,9
B20	63,8 ml/rev	1000	63,8	58,3	53,8	1,6	15,8	27,0
		1500	95,7	90,2	85,7	2,2	23,8	40,2
B22	70,3 ml/rev	1000	70,3	64,8	60,3	1,7	17,3	29,6
		1500	105,4	100,0	95,5	2,3	26,1	44,1
B25 ¹⁾	79,3 ml/rev	1000	79,3	73,8	69,3	1,8	19,3	33,2
		1500	118,9	113,5	109,0	2,5	29,2	49,5
B28 ¹⁾	88,8 ml/rev	1000	88,8	83,3	80,1 ²⁾	1,9	21,9	32,5 ²⁾
		1500	133,2	127,7	124,5 ²⁾	2,8	32,7	48,5 ²⁾
B31 ¹⁾	100,0 ml/rev	1000	100,0	94,5	91,3 ²⁾	2,0	24,4	36,4 ²⁾
		1500	150,0	144,5	141,3 ²⁾	2,8	36,5	54,4 ²⁾

¹⁾ B25 - B28 - B31 = 2500 R.P.M. max.

²⁾ B28 - B31 = 210 bar max. int.

- Not to use because internal leakage greater than 50% theoretical flow. Maximum permissible axial load $F_a = 800$ N. Port connection can be furnished with metric threads